



PRODUCT BULLETIN MODEL WS SUMP PUMPS

OVER 130 YEARS

American-Marsh Model WS Sump Pumps are used in a variety of industries. These rugged and efficient centrifugal pumps are designed for long life and low operational costs. American-Marsh has been building pumps for over 130 years. This long experience is responsible for the superior performance of the Model WS Sump Pumps.

Casings and impellers have been carefully designed for quiet operation. Units are assembled complete at our factory to eliminate all difficulty during installation.

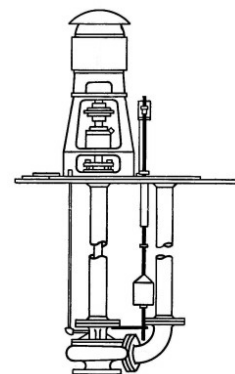

Material Specifications

PART	CONSTRUCTION			
	STANDARD FITTED	BRONZE FITTED	NI-RESIST FITTED	316SS FITTED
Casing	Cast Iron	Cast Iron	Cast Iron	Cast Iron
Impeller	Cast Iron	Bronze	Ni-Resist	316 Stainless Steel
Pump Shaft	416 Stainless Steel	416 Stainless Steel	416 Stainless Steel	316 Stainless Steel
Stuffing Box Gland	Cast Iron	Cast Iron	Cast Iron	316 Stainless Steel
Inboard Head	Cast Iron	Cast Iron	Cast Iron	Cast Iron
Bearing Cap	Cast Iron	Cast Iron	Cast Iron	Cast Iron
Bolts, Studs & Nuts	Steel	Steel	Steel	Steel
Support Pipe and Discharge Pipe	Steel	Steel	Steel	Steel

MODEL WS SPECIFICATIONS

Casing: The casing is constructed of high tensile cast iron or other specified material. It is of the volute type, carefully and accurately proportioned to permit smooth flow and to convert high velocity energy of the fluid as it leaves the impeller into pressure. Suction and discharge nozzles are cast integral with the volute. Necessary vent and drain openings are provided.

Impeller: Impellers are of the side suction enclosed type, for clockwise rotation, and have only two blades. They are properly rounded at the inlet and keyed to the shaft in such a way as to eliminate any danger of clogging. The impellers will pass sewage, heavy liquid, storm drainage, rags, as well as solids, one pipe size smaller than the discharge opening of the pump.

Inboard Head: The inboard head is constructed of cast iron or other specified material. The inboard head connects the fluid end to the support pipe and contains the inboard head bushing.

Shaft: The shaft is of 416 stainless steel, polished and of large diameter to prevent vibration. Lineshaft bearings are spaced to

minimize shaft deflection. The shaft is supported by the thrust bearing housing, located at the surface plate, which has integral lateral adjustment.

Support & Discharge Pipe: The support pipe is of black iron, one end flanged to the inboard head and the other end flanges to the sump cover. Intermediate bearings will be flanged between multiple pieces of support column and spaced accordingly. The discharge pipe is flanged, one end connected to the discharge elbow and the other to the system piping.

Discharge Elbow: The discharge elbow is of high tensile cast iron or of other specified material and of the long radius type flanged to the discharge of the casing and to the discharge pipe assembly.

Sump Cover: The sump cover is of carbon steel, teardrop or of other shape as desired. The sump cover supports the entire weight of the complete pump assembly.

INDUSTRIAL
Spill Containment, Processing,
Leachate Recovery, Bilge

COMMERCIAL
Condensate Recovery, Breweries,
Contact Water

MUNICIPAL
Sump, Lift Stations, Transfer,
Filter Backwash

**PRODUCT BULLETIN
MODEL WS SUMP**

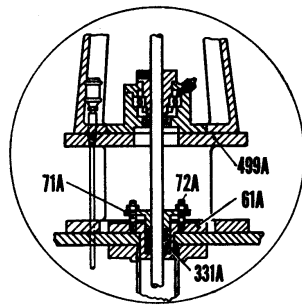

Construction with Stuffing Box at Coverplate

Intermediate Sleeve Bearing Construction used on Pit Depths Over Six Feet

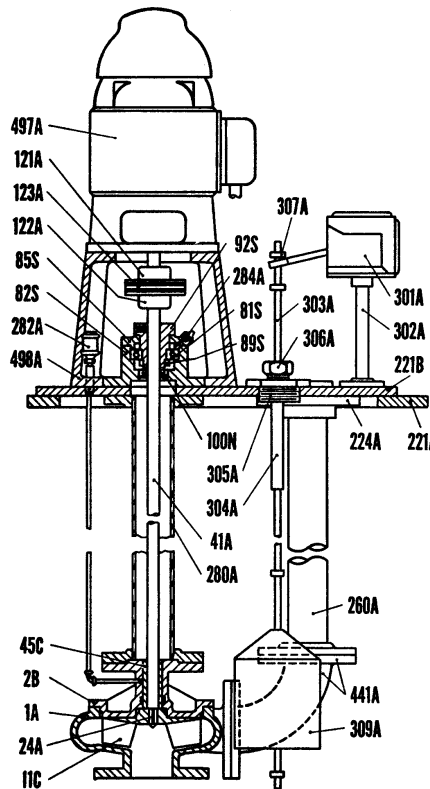
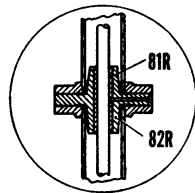

WS Sectional Drawing

Item Number	Item Description	Num. Req.
1A	Casing	1
2B	Head, Upper Casing	1
11C	Impeller	1
24A	Key, Impeller	1
41A	Shaft, Pump	1
45C	Bearing, Casing Head	1
61A	Box, Stuffing	1
71A	Gland, Stuffing Box	1
72A	Stud, Gland, with Nut	2
81R	Bearing, Intermediate	Varies
81S	Bearing, Ball Thrust	1
82R	Housing, Intermediate Bearing	Varies
82S	Housing, Ball Bearing	1
85S	Cap, Bearing Housing	1
89S	Locknut, Ball Bearing	1
*91S	Lockwasher, Ball Bearing	1
92S	Adapter, Ball Bearing	1
100N	Ring, Lube Seal	1
121A	Coupling, Motor	1
122A	Coupling, Pump	1
123A	Disc, Coupling	1

Item Number	Item Description	Num. Req.
221A	Plate, Sump Cover	1
221B	Plate, Sump Mounting	1
224A	Flange, Upper Discharge	1
260A	Pipe, Discharge, Assembly	Varies
280A	Pipe, Support, Assembly	Varies
282A	Oiler	Varies
284A	Fitting, Zerk Grease	1
**301A	Switch, Float	1
302A	Bracket, Float Switch	1
303A	Rod, Float	1
304A	Guide, Float Rod	1
305A	Box, Float Rod Stuffing	1
306A	Gland Nut, Float Rod Box	1
307A	Stop, Float Rod	4
309A	Float	1
331A	Packing, Stuffing Box	1 set
*332A	Packing, Float Rod Box	1 set
441A	Elbow, Discharge	1
**497A	Motor	1
498A	Pedestal, Motor	1
499A	Pedestal, Extension	1

* Not Shown in sectional

** Not supplied as standard but can be ordered as an option.

Recommended spare parts are in **BOLD**.